

**Thank you again for
choosing this product!**

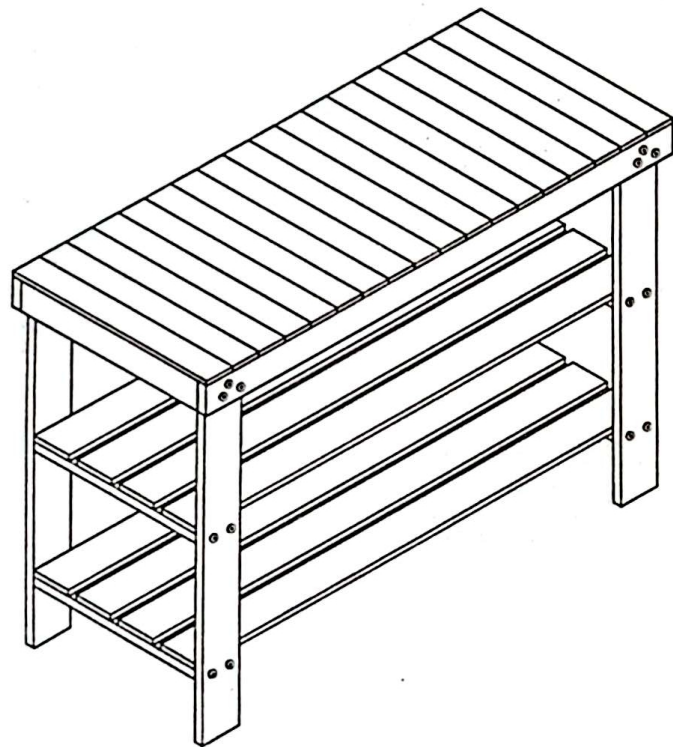

All of us do appreciate your product purchase. We hope that you are as happy with your product as we designing and manufacturing it for you. We strive to provide you with the best quality products and services in the industry. If you have any questions please don't hesitate to contact us at

Technical Support:

(US/CA)1-800-556-9829 Mon-Fri 8am - 8pm(CST)

(UK)44-808-196-3885 Mon-Fri 2pm - 10pm(UTC)

Other Info: support@pipishell.net

Website: www.pipishellav.com

**Shoe Rack Bench Instruction Manual
V3.0(D)**

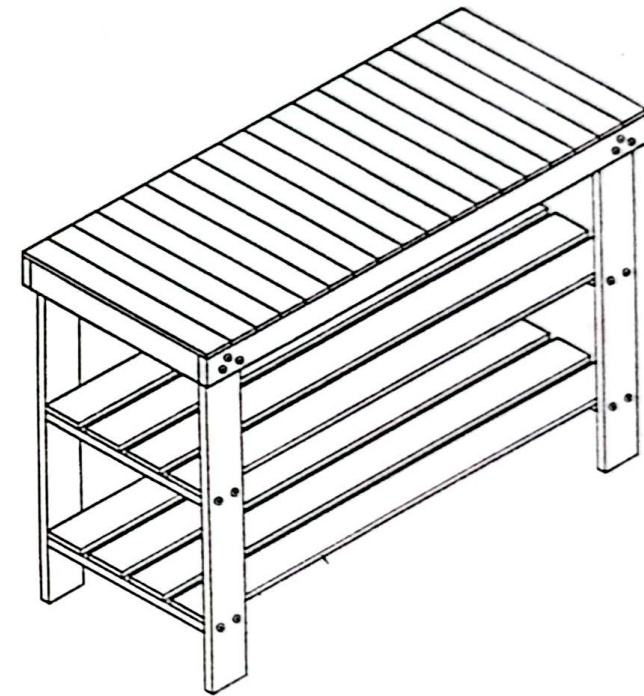

Model: PISRB1/PISRB2

Thank you for choosing this product! We strive to provide you with the best quality products and services in the industry. Should you have any issues, please don't hesitate to contact us at

Technical Support:

(US/CA)1-800-556-9829 Mon-Fri 8am - 8pm(CST)

(UK)44-808-196-3885 Mon-Fri 2pm - 10pm(UTC)

Other Info: support@pipishell.net

Website: www.pipishellav.com

Supplied Parts and Hardware

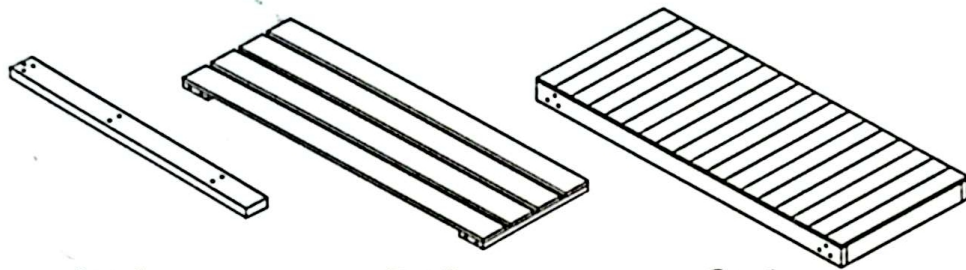

A x 4

B x 2

C x 1



M6x25 mm
D x 12



M6x45 mm
E x 16



5/32 in (4mm)
F x 1

STEP 1

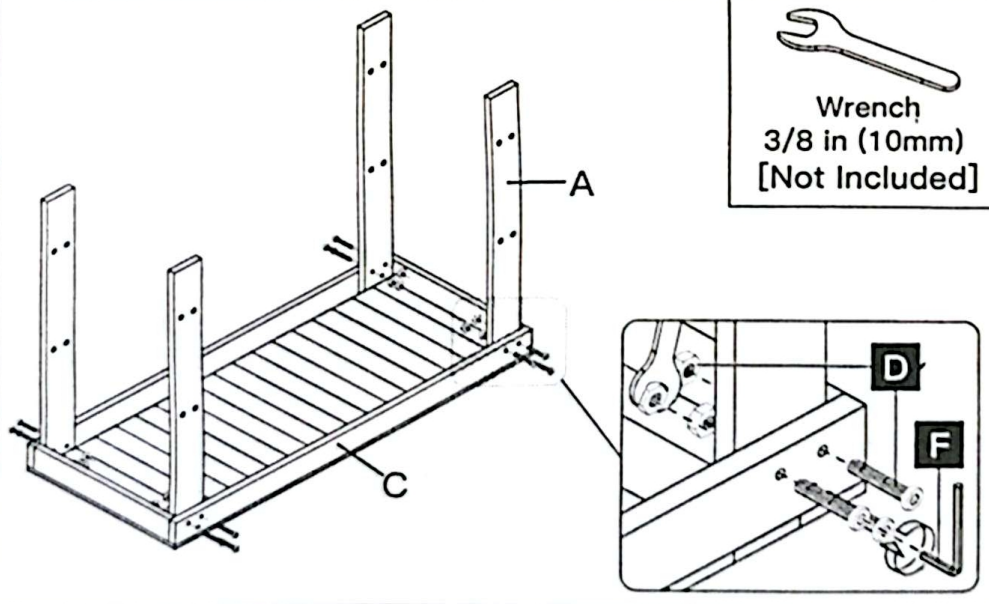

Wrench
3/8 in (10mm)
[Not Included]

01

STEP 2

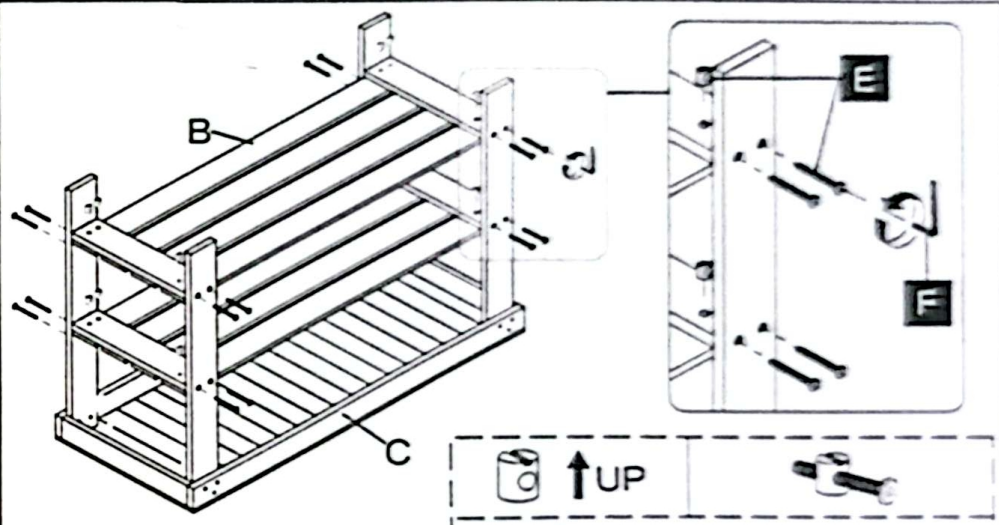

Note: The hole of cam lock nut should be aligned with the direction of the screw goes in. Ensure the screw can go through the hole of the cam lock nut.

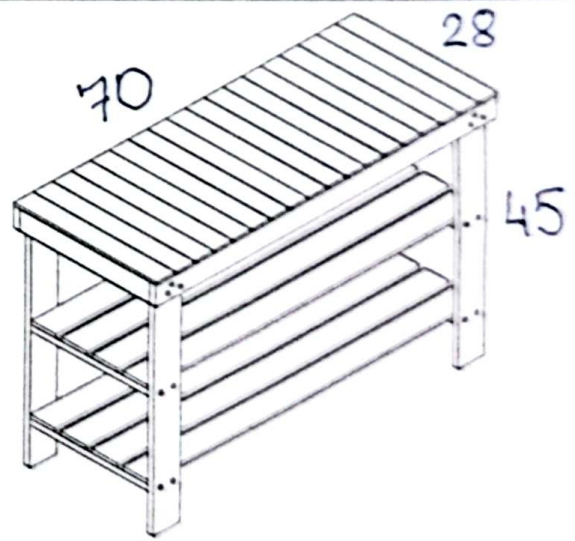

02